

# TVC-TRF-10-RT

Full option module with sound for RC armored recovery vehicles in 1/16th to 1/25th scale

This module was developed to enable complete control of armored recovery vehicles with lifting crane and dozer blade.

The integrated mode level switching allows the entire model to be controlled with an RC system with only 4 channels. To use all possibilities 8 channels are needed.

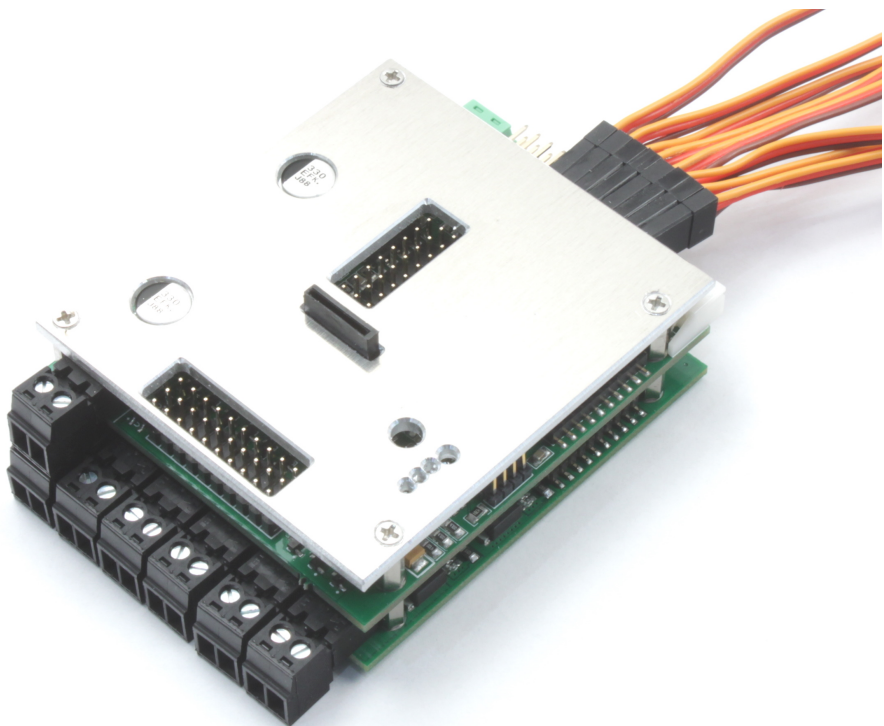



## 1 Note

Installation of the module requires intermediate to advanced modeling skills. Soldering skills are required to connect the wiring. Inexperienced modelers and persons aged under 16 years old should seek the assistance of an experienced modeler. Always switch off power when working on the wiring. Especial take care when connecting more than one receiver energy source. Prevent the device from getting wet. Check loads before connecting them to the modul at a current limited, or fuse protected source.

# Contents

<b>1</b>	<b>Note</b>	<b>2</b>
<b>2</b>	<b>Introducing</b>	<b>7</b>
2.1	FO modul features . . . . .	7
2.2	technology . . . . .	8
2.3	scope of delivery . . . . .	8
2.4	accessories . . . . .	8
2.5	Overview . . . . .	9
2.5.1	build in functions . . . . .	9
2.6	Radio requirements . . . . .	9
2.6.1	usable radios . . . . .	9
2.6.2	best practice . . . . .	10
<b>3</b>	<b>function</b>	<b>12</b>
3.1	manual control . . . . .	13
3.1.1	channel 1 . . . . .	13
3.1.2	channel 2 . . . . .	13
3.1.3	channel 3 . . . . .	13
3.1.4	channel 4 . . . . .	14
3.1.5	channel 5 . . . . .	14
3.1.6	channel 6 . . . . .	14
3.1.7	channel 7 . . . . .	15
3.1.8	Channel 8 Controlling the volume . . . . .	15
3.2	Function of the light mode control . . . . .	15
3.2.1	Lightmode 1 . . . . .	15
3.2.2	Lightmode 2 . . . . .	16
3.2.3	Tip 2 . . . . .	17
3.3	Automatic functions . . . . .	17
3.3.1	MG . . . . .	17
3.3.2	automatic engine stop . . . . .	17
3.4	drive-dynamic functions . . . . .	18
3.4.1	Exhaust simulation module . . . . .	18
3.4.2	Reverse light . . . . .	18
3.4.3	Rotating flasher light . . . . .	18
3.4.4	Turn signals . . . . .	19

3.4.5	Brake light . . . . .	19
<b>4</b>	<b>Connector overview</b>	<b>20</b>
4.1	Connection of batteries cable (X60) . . . . .	20
4.2	Inputs . . . . .	21
4.2.1	connection to the receiver (X50 to X57) . . . . .	21
4.2.2	IBUS (X50) . . . . .	21
4.2.3	SBus (X50) . . . . .	22
4.2.4	SUMD sum signal (X50) . . . . .	22
4.2.5	PPM (X50) . . . . .	22
4.2.6	Multiswitch Module (X50 to X56 and X57) . . . . .	22
4.3	connection of the servo outputs (X40 to X47) . . . . .	23
4.4	motor and servo outputs overview . . . . .	23
4.4.1	Connection of servo or gear motor for elevating the crane boom . . . . .	24
4.4.2	Connection of gear motor for elevating the crane hoist which . . . . .	24
4.4.3	Connection of servos or gear motor for rotating the crane . . . . .	24
4.4.4	Connection of servos or gear motor for the dozer blade . . . . .	24
4.5	connection of the motors (X01 - X04 & X20 - X21) . . . . .	24
4.6	connection of drive motors . . . . .	25
4.6.1	SGS Drives . . . . .	25
4.7	connection of the switch outputs (X08 to X17) . . . . .	27
4.7.1	Connection of lighting and exhaust systems . . . . .	28
4.8	Connecting the speaker (X70) . . . . .	29
<b>5</b>	<b>Initialization</b>	<b>30</b>
5.1	turn on sequence . . . . .	30
5.2	operation modes . . . . .	30
<b>6</b>	<b>changing sound and software</b>	<b>31</b>
6.1	Changing the sound . . . . .	31
6.2	Changing the software . . . . .	31
<b>7</b>	<b>Practical tips</b>	<b>33</b>
7.1	Neutral position . . . . .	33
7.2	Failsafe receiver . . . . .	33

7.3	Do not use provisionally methods of connectivity . . . . .	33
7.4	Work on the wiring . . . . .	33
7.5	Rotating flasher . . . . .	34
7.6	Connecting LED . . . . .	34
<b>8</b>	<b>Glossary of terms</b>	<b>36</b>
<b>9</b>	<b>Technical data</b>	<b>38</b>
<b>10</b>	<b>Important</b>	<b>39</b>
10.1	Warning . . . . .	39
10.2	Environmental protection . . . . .	39
10.3	Address . . . . .	40
10.4	Contact . . . . .	40
10.5	Document date . . . . .	40
10.6	Documentation . . . . .	40

## List of Figures

1	example radio stick assignment . . . . .	12
2	connector overview . . . . .	20
3	battery cable shown with polarity . . . . .	20
4	servo connector signals . . . . .	21
5	orientation servo input cables to the receiver . . . . .	21
6	Futaba servos have a plastic nozzle that has to be removed . . . . .	23
7	orientation servo output cables . . . . .	23
8	motor connectors . . . . .	25
9	When our transmission is built into the front of the vehicle, the left motor (in driving direction) is connected to X01. White wire to X01- , green wire to X01+. The right motor (in driving direction) is connected to X02. White wire to X02+, green wire to X02-. . . . .	25
10	When our transmission is built into the back of the vehicle, the left motor (in driving direction) is connected to X01. White wire to X01- , green wire to X01+. The right motor (in driving direction) is connected to X02. White wire to X02+, green wire to X02-. . . . .	26

11	switch outputs . . . . .	27
12	speaker connector . . . . .	29
13	position and orientation of the $\mu$ SD card slot . . . . .	32
14	rotating flasher wiring . . . . .	34
15	LED resistor . . . . .	35
16	resistor for LED groups . . . . .	35

## List of Tables

1	Lightmode 1 . . . . .	16
2	Lightmode 2 . . . . .	17
3	motor and servo outputs overview . . . . .	24
4	Allocation of terminal posts for the lights, exhaust fan, and heater . . . . .	28
5	boot-loader error codes . . . . .	32
6	Abbreviation for the manipulators in the transmitter housing	37

## 2 Introducing

This modul for recovery tanks is based on our 3th generation of the full option modul. This module comes with a wide range of in- and outputs and is therefore suitable for a wide varetly of models. The user can switch the function between any of the model types just by loading the software provided on our website

- Trucks
  - trailer trucks
  - tank transporter trucks
  - spezial function trucks
- construction machines
  - dumper trucks
  - hydraulic excavators
  - rope excavators
  - dozers
- tanks
  - main battle tanks mbt/pso
  - recovery tanks
  - anti aircraft tanks
  - armored person carrier
  - excavator tanks
  - amphibious tanks
- snow forming tracked vehicles
- tugs

### 2.1 FO modul features

- 6 integrated ESC with a drive capability of 2x10A and 4x3A, clocked with 16kHz
- audio subsystem with 15W amplifier , volume can be controlled by a trimmer or a rc chanel
- 20 light output chanel
- 8 servo outputs

- 4 inputs for sensors (e.g. gepard radar parking pos sensor)
- maximum control channel count is 16; PPM, S-Bus, I-Bus are supported
- sounds and firmware can be loaded using a uSD card to change the modules function to all kind of model software we provide

## 2.2 technology

The controller is rated for an input of 7.2V to 16V. A 10A fuse protects the module and the battery from over current. Integrated fail safe functions prevent unintended operation of the model.

An internal BEC generates 5V to supply the receiver. The receiver is supplied through the servo cables. The modul internally operates with 3.3V.

## 2.3 scope of delivery

Connecting cables and plugs are supplied with the module, which must be connected/soldered on the load side:

- servo leads for receiver connection
- green connector for power supply X60
- black connector for speaker X70
- black connectors for X01 to X04, X20 and X21

## 2.4 accessories

Connecting cables for outputs X08 to X17 (light, smoke generator, etc.) are NOT included in the delivery. These outputs can be used with standard three-pin servo leads. We offer different contacting options for this in the accessories.

- **FO-LS10** universal cable set with 8 servo leads, cable ties and 8 series resistors for LED
- **FO-AD13** universal adapter with contact spring force clamps
- **TVC-TRF-AD4** Adapter for connectors of the electrical system in Tamiya truck models



## 2.5 Overview

### 2.5.1 build in functions

This module will provide the following functions:

- proportional drive motor control with two mixing integrated speed controllers
- proportional crane rotation with servo output and speed control
- proportional crane elevation with servo output and speed control
- crane hook elevation with servo output and speed control
- dozer shield elevation with servo output and speed control
- main gun fire with led strobe
- polyphonic sounds for all functions (engine start/stop/idle, 14 drive stages, main gun, MG, turret turn, barrel elevation)
- automatic control of brake light, reverse light, flashing light
- zwei schaltbare Lichtausgänge
- switching between up to three models
- automatic control of smoke pump and heating element
- Volume control by RC or at the modul

## 2.6 Radio requirements

### 2.6.1 usable radios

All common FM and 2.4GHz RC radios are supported. No special functions or mixers are required in the transmitter. The simpler the radio, the easier the commissioning.

In order to be able to control as many variants as possible, some functions of the FO module work by storing operation modes or by differentiate the speed of with which the stick is moved from the middle position.

For channels operating this way it is important that they are triggered starting from the middle position.

This is for non-self-resetting channels, like

1. linear knobs
2. rotary knobs
3. non self centering sticks (throttlet chanel for RC planes)

not automatically the case. An operation of the above functions should be done with

1. three stage momentary switch
2. self centering sticks

In table 3.1.8 you can find the suggest kind of control elements for each chanel.

**Note** Not self centering control elements must be placed in mid position befor turning on the FO Modul.

### 2.6.2 best practice

We recommend testing the channels of your radio before installing the module.

Most radios today have their focus on operating RC planes. Control elements are often not (all) intended to directly output their switching state. Their primary task in flight radios is to manipulate the function / parameters of the mixers built into the transmitter.

The failsafe function (if available) should be set to output the mid position of all chanel.

The transmitter should not be set on the FO module. The servo travel indicator on the transmitter display is more suitable, or a test setup with servos connected directly to the receiver.

You can observe the following behavior:

1. on a self centering stick a servo follows the movement of the stick. If you let the stick go, the servos moves to mid position.

2. having a linear or rotary knob on the channel a servo follows the movement and stays there even after untouching the control element
3. with a three stage switch a servo can be moved to three positions. left, mid, right. As the switch doesn't move if you let it go, the servo will not move also.
4. using a three stage momentary switch a servo can also be moved to three positions, but it returns to mid after releasing the switch.

### 3 function

A proportional radio transmitter is required. It needs at least four channels and max. eight channels. The channels 5,6,7 and 8 can be plugged optional. To have maximum degree of freedom in controlling the crane, the module can operate in three control modes that can be switched any time using one channel on your RC.

1. recovery mode
2. driving mode
3. dozer mode

This enables you to use the sticks to do precision control of all drives.

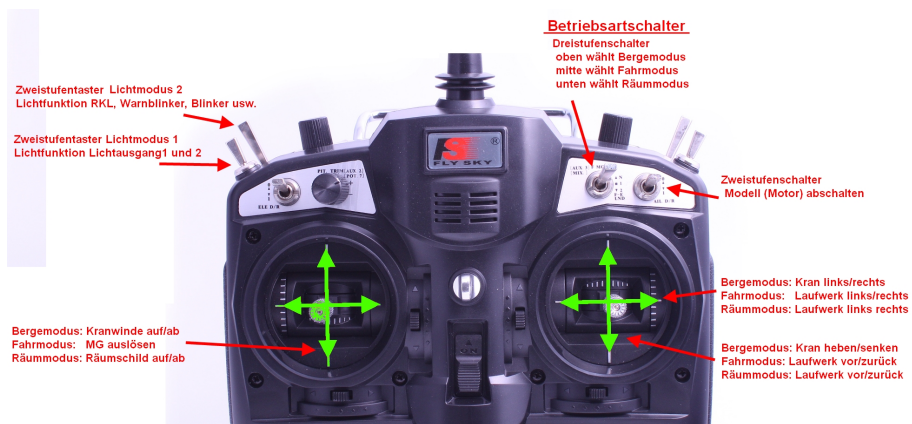

Figure 1: example radio stick assignment

## 3.1 manual control

Please note, we use the naming convention **channel**, but this does not mean, that channel one of our module must be connected to your receiver channel one. You are free in assignment.

### 3.1.1 channel 1

**driving mode und dozer mode** *Proportional left/right with integrated V-mixer* The integrated mixer slows the inside track to a full stop. Deflection of the stick while stopped causes the vehicle to pivot steer. (This channel provides turn signal information)

**recovery mode** *crane turntable*

In lifting mode channel 1 controls operation of the crane turntable. There is a DC-Motor output and a servo output.

### 3.1.2 channel 2

**driving mode** *Proportional forward/reverse*

This channel also provides the information for brake and reverse lights, and smoke generator.

**dozer mode** *Proportional forward/reverse*

**recovery mode** *Lifting the boom*

There is a DC-Motor output and a servo output.

### 3.1.3 channel 3

**driving mode** *Horn MG operation* In the upper third of the range of deflection the MG sounds and the LED flashes. In the lower third of the range

of deflection the horn sounds. This is only active when channel 7 is not plugged.

**dozer mode** *Dozer blade up/down*

There is a DC-Motor output and a servo output.

**recovery mode** *Hoist elevation*

Hoist elevation controls a gear motor with a proportional speed control

### 3.1.4 channel 4

*This channel defines the control modes* This channel provides mode control selecting between the 3 operating modes.

### 3.1.5 channel 5

**Controlling the light mode** Using this channel, the rotating flasher, the flasher can be controlled. In addition there are two lamp outputs that can be used for individual switch functions, e.g. light or beamers lamps.

### 3.1.6 channel 6

Case the model is switched off by leaving the neutral position, the model stops running when channels 1 to 5 are controlled and the engine off sound is played. This feature can be used to play the engine start/stop sound by the RC. But it can be used to switch between up to three different models. To achieve that, the appropriate model must be switched on, when the channel 6 switch is positioned in a unique position. The module stores this position as "turn on" position. When the switch leaves this position, the model becomes passive and can not be moved. Using this channel is optional.

### 3.1.7 channel 7

**Controlling horn and MG** In the upper third of the range of deflection the MG sounds and the LED flashes. In the lower third of the range of deflection the horn sounds. Using this channel is optional.

### 3.1.8 Channel 8 Controlling the volume

If this channel is connected to a receiver, volume is controlled using this RC channel. Otherwise the volume is controlled with Trimmer P1.

chan- nel	Stecker	op- tional	radio	re- cov- ery mode	driving mode	dozer mode
1	X50	no	StickS	crane	steering turntable	steer- ing
2	X51	no	StickS	crane boom	throttle	throt- tle
3	X52	no	StickS	hoist winch	MG / horn	dozer blade
4	X53	no	TSS	control mode selection		
5	X54	yes	TSMS	light mode control		
6	X55	yes	TSS	model select		
7	X56	yes	TSMS	MG / horn		
8	X57	yes	Pot	volume control		

## 3.2 Function of the light mode control

There are two light modes light mode 1 and light mode 2. They are controlled independently with one RC channel.

### 3.2.1 Lightmode 1

Lightmode 1 for auxiliary output 1 and 2. They can be used for combat light, beam light or any other consumer.

for auxillary output 1 and 2. They can be used for combat light, beam light or any other consumer. The mode is count up , (1 → 2 → 3 → 4 → 1 and so on). When keeping the stick for about 2 seconds, the lightmode is reset to 1(all off).

Zustand	1	2	3	4
auxlight 1	off	On	off	On
auxlight 2	off	off	On	On

*Table 1: Lightmode 1*

### 3.2.2 Lightmode 2

The lightmode 2 controls the automatic functions of the warnblinker and the rotating flasher. The lamp function is given by the table below. The modes are called:

- road traffic 1
- road traffic 2
- road traffic 3
- combat 1

For example the turn flasher is not activated automatically in combat mode, while it is activated in road traffic 1 and 2 when steering.

The lightmode 2 is changed by tipping the stick backwards. The mode is count up *road traffic 1* → *road traffic 2* → *road traffic 3* → *combat* → *road traffic 1, and so on*. When keeping the stick for about 2 seconds, the lightmode 2 is reset to "road traffic1".

The light modes states are stored when changing the operation mode. When the model is switched off by the model selector channel, all light states are unchanged.

When the model is parked by turning of the transmitter, all light are turned off.

When using the battle-system, the four rotating lights are also activated in a random way for about three seconds when the tank is hit by the battlesystem.



Zustand	road fic 1	traf- fic 2	road traf- fic 3	combat
brake light	auto	auto	auto	off
combat brake light	off	off	off	auto
blinker left and right	auto	auto	Warning flasher	off
rotating light 1,2,3,4	off	on (rotat- ing)	on (rotat- ing)	off

Table 2: Lightmode 2

### 3.2.3 Tip 2

Typically, a three-stage switch is used on the transmitter. Proportional channels with linear knobs may complicate the selection of the light mode, because the indexing is done by briefly returning to the center position. This may be difficult with linear knobs.

## 3.3 Automatic functions

### 3.3.1 MG

The MG light flashes at approximately two times per second when shooting and the sound module plays the recorded MG sounds.

### 3.3.2 automatic engine stop

In case the radio is unoperated for about 2 minutes, the module turns off the engine and plays the engine stop sound. Additionally the exhaust simulation is switched off. (parking mode)

To wake the module, just move the throttle stick, then the engine startup sound will be played and all functions are available again.

When the module is in parking mode, random sounds are played. E.g. this can be sound from construction machines, music or walkie talkie noise. These sounds, like all others on the module, can be changed.

You can also change to the parking mode by turning off the radio. When doing this, no random sound is played.

### **TIP**

- If no warmstart sound can be found, the cold start sound will be played.
- If you use a failsafe receiver, the receiver delivers signal output when the radio is turned off. For that reason the module can not detect the unpowered radio. Please turn off failsafe function or use a normal receiver.

## **3.4 drive-dynamic functions**

### **3.4.1 Exhaust simulation module**

The module will control a liquid smoke heater and pump/fan. The smoke liquid heater is switched on when the model receives a valid radio signal. The outputs for the blowers and pump are operated as a function of acceleration and speed. At idle the smoke is inactive. As the model accelerates, smoke increases proportional to setting and duration of the throttle. During steady throttle travel the output is reduced by 50% (by means of PWM)

### **3.4.2 Reverse light**

The reverse light output is linked to channel 2 and is automatic. As soon as the throttle lever (channel 2) is in neutral or forward position is, the reverse light is switched off.

### **3.4.3 Rotating flasher light**

The flasher runs constantly with approx. 1.5 cycles per second. When signal faults occur or when the transmitter is switched off the flasher stops.

#### **3.4.4 Turn signals**

Starting from a minimum of 10% throttle the signal lights will flash left or right as required. Das Warnblinklicht kann durch den Lichtmodus 2 ein- oder ausgeschaltet werden.

#### **3.4.5 Brake light**

The brake light is automatic. Lights go out automatically with resumed throttle.

## 4 Connector overview

This section gives you an overview of the connectors. The exact function of each connector can be found below.

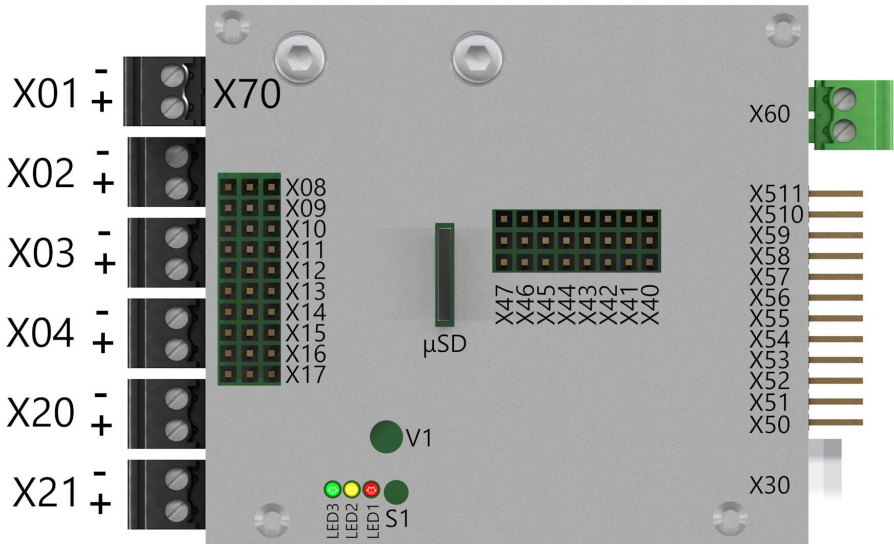

Figure 2: connector overview

### 4.1 Connection of batteries cable (X60)

The connection is made with the green contact block. The connector is (X60). It is a good practice to install a switch between battery and the power connector.

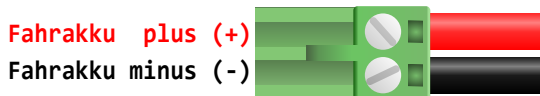

Figure 3: battery cable shown with polarity

## 4.2 Inputs

### 4.2.1 connection to the receiver (X50 to X57)

The connection to the receiver is made using jr patch cables. One side is plugged into the module and one side is connected to the receiver.

picture 5 shows how the connectors are plugged into the module. The ground (black or brown line of the servo cable) is closest to to the bottom of the module. Most receivers have no mechanical polarity protection, so double check polarity.

If the delivered cables does not match the length needed, they can simply be replaced by longer or shorter versions.



Figure 4: servo connector signals

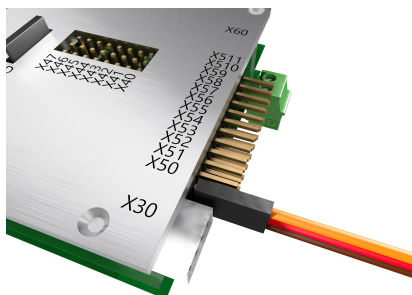

Figure 5: orientation servo input cables to the receiver

The module has an integrated BEC, so no additional BEC is needed. But if you want to use one, or you have an additional ESC that has one integrated, please do not operate your model with more than one BEC unit. This may lead into damage if one of the BEC units is a switching voltage regulator (SBEC). In this case pull the +5V (red) cable from all servo cables and isolate them with a tape or shrink wrap.

### 4.2.2 IBUS (X50)

If the module is operated on an IBUS receiver, this is connected to X50. Via the IBUS, a maximum of 14 channels can be used by the FO.

### 4.2.3 SBus (X50)

If the receiver has an SBus interface, it is connected to X50. If the receiver has a *in* and *out* signal, the *out* signal must be used. X51 is reserved for the *in* signal, but this is not supported yet. A maximum of 18 channels can be used via the SBUS.

### 4.2.4 SUMD sum signal (X50)

If the receiver has an SUMD interface, it is connected to X50. A maximum of 16 channels can be used via the SUMD

### 4.2.5 PPM (X50)

If the module is operated on a PPM output (also known as sum signal or teacher/student signal), this is connected to X50. PPM8 is supported, which means that a maximum of 8 channels can be used by the FO.

### 4.2.6 Multiswitch Module (X50 to X56 and X57)

The module can handle the multiswitch protocols of the old Graupner Nautic-Expert and Robbe multi-decoder on X57. These were used in FM systems to transmit up to 8 additional channels over one RC channel.

Unfortunately, this useful technology was not adopted by the manufacturers of 2.4GHz systems, but the 2.4GHz retrofit modules from Jeti support it.

There are also modules that combine channels for special receivers and output them as a multiswitch signal.

With the Multiswitch option, a maximum of 15 channels can be used by the FO.

### 4.3 connection of the servo outputs (X40 to X47)

The servos that are controlled by the module are connected to the connectors X40 to X47. Picture 7 shows the orientation of the connector. The ground (black or brown line of the servo cable) is closest to the center of the module.

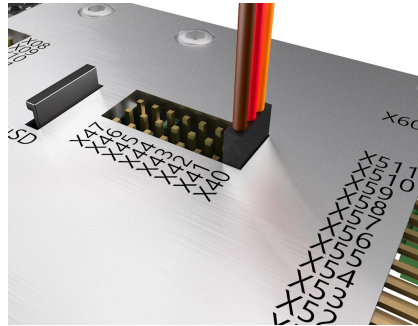
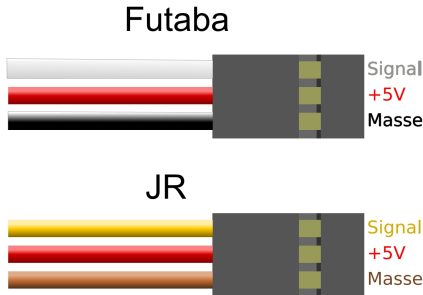

Figure 6: Futaba servos have a plastic nozzle that has to be removed  
 Figure 7: orientation servo output cables

The last servo position is stored with the module memory. Because of that you do not have to expect bis servo moves when powering the module. However, when powering the model, a short servo move may happen.

Make sure your servos can achieve the required position. When servo travel is blocked current flow can be 300-500 mA instead of the usual 40mA at rest. This can lead to high temperatures of the module, because the BEC has to deliver high currents.

Servo outputs that operate in parallel to a motor output behave like a gear motor. Stick deflection results in rotation in proportion to motion. Release the stick and the servo stops without returning to zero position. For that reason only servos must be plugged in to this channels. ESCs plugged to this channels will not stop when returning to neutral, as most one would expect.

### 4.4 motor and servo outputs overview

<b>Funktion</b>	<b>servo connector</b>	<b>motor connector</b>
track motor 1		X01
track motor 2		X02
dozer blade	X40	X03
crane boom	X41	X04
crane turntable	X42	X20
cran hoist winch	X43	X21

*Table 3: motor and servo outputs overview*

#### **4.4.1 Connection of servo or gear motor for elevating the crane boom**

The crane boom motor can be plugged to X04. In addition to this motor output the module provides a servo outputs for crane boom (X41) that can be used alternative.

#### **4.4.2 Connection of gear motor for elevating the crane hoist winch**

The crane hoist winch can be plugged to X21.

#### **4.4.3 Connection of servos or gear motor for rotating the crane**

The crane turntable motor can be plugged to X20. In addition to this motor output the module provides a servo outputs for crane turntable (X42) that can be used alternative.

#### **4.4.4 Connection of servos or gear motor for the dozer blade**

The dozer blade can be plugged to X03. In addition to this motor output the module provides a servo outputs the dozer blade (X40) that can be used alternative.

### **4.5 connection of the motors (X01 - X04 & X20 - X21)**

motors are connected with black, plugable connectors.



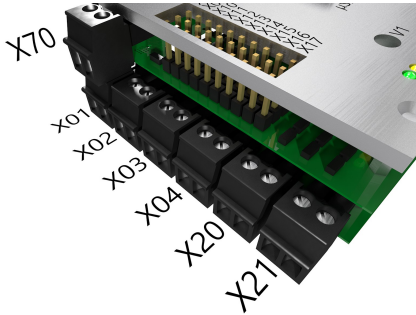
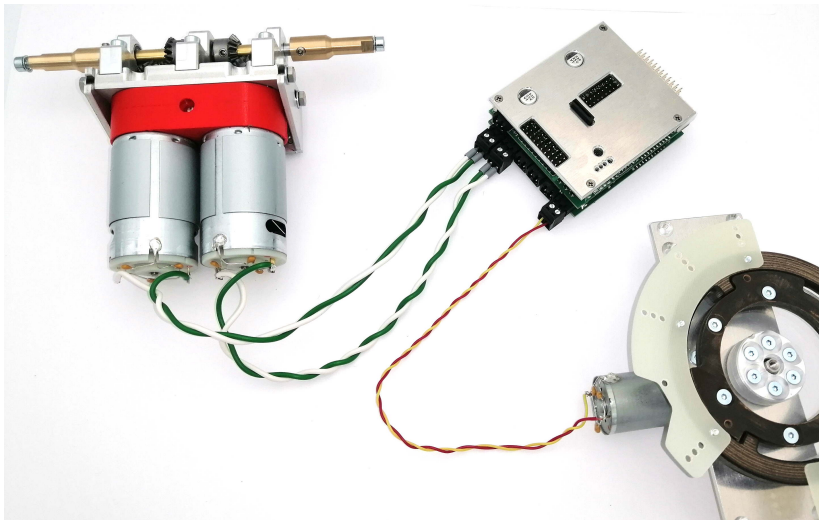

Figure 8: motor connectors

## 4.6 connection of drive motors

The drive motors are attached to X01 and X02 at the black plug in connectors. The motors must be properly radio-interference-suppressed (install capacitors if required).

### 4.6.1 SGS Drives



*Figure 9: When our transmission is built into the front of the vehicle, the left motor (in driving direction) is connected to X01. White wire to X01- , green wire to X01+. The right motor (in driving direction) is connected to X02. White wire to X02+, green wire to X02-.*

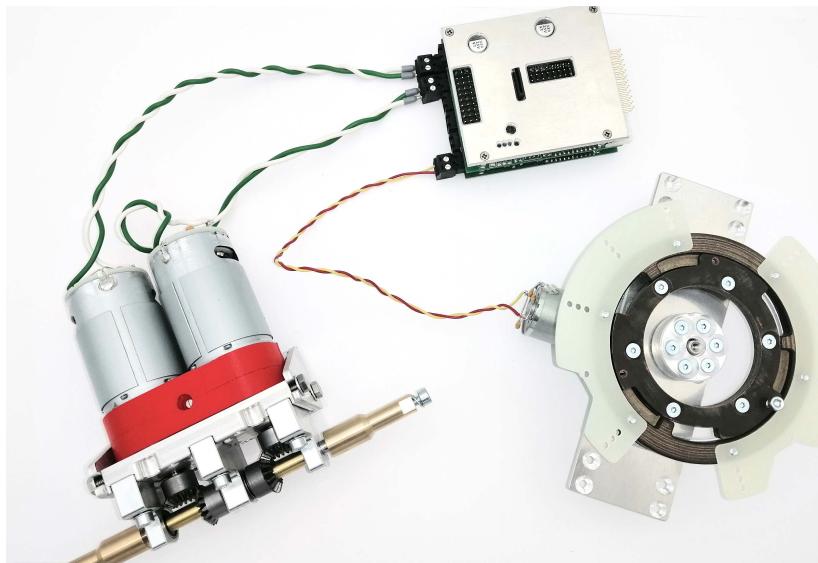

*Figure 10: When our transmission is built into the back of the vehicle, the left motor (in driving direction) is connected to X01. White wire to X01- , green wire to X01+. The right motor (in driving direction) is connected to X02. White wire to X02+, green wire to X02-.*

drives of other manufacturers Please make sure that they do not swap the channels for steering and throttle.

This can easily lead to confusion when determining the direction of travel of the engines.

It is best to connect the turn signals and reversing lights for checking.

Correct if necessary by servo reverse in the transmitter forward/backward or left/right.

When connecting the motors, proceed as follows:

1. Take the model chassis and a battery.
2. jack up the chassis.

- do the following without any installed electronic components a battery directly to the right motor (in relation to the forward direction of the model) so that the chain goes forward. Mark the motor connection wire, which must be connected to the positive pole of the battery, with a + . Mark the other motor connection line with - .
- Do the same for the left motor.
- On the right motor, connect the wire marked + to X01+ and the wire marked - to X01-.
- On the left motor, connect the wire marked + to X02- and the wire marked - to X02+.

**Note 2** With the software version for *mechanical* Superimposed gearboxes, connect the straight drive motor to X01 and the steering drive to X02. Mechanical superimposed gearboxes mix drive and steering motion via a gear differential. They are designed as a mechanical unit for both chains, while drives for electronic mixers have a gearmotor for the left and right chains.

#### 4.7 connection of the switch outputs (X08 to X17)

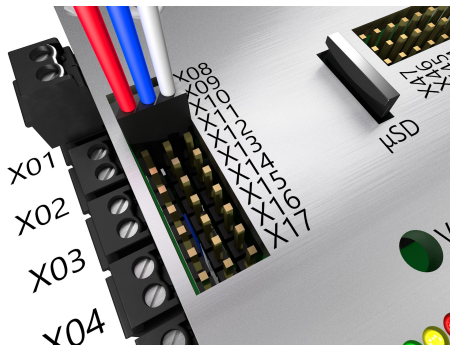

Figure 11: switch outputs

The switch outputs are used for light- and simple motor functions. Each connector has two outputs (blue and grey) and one common connection (red).

The switch outputs **X08 and X09** switch to battery + . The common connector is connected to ground.

The switch outputs **X10 to X17** are switched to ground. The common connector is connected to battery +.

**Tip** The left connection (permanent +) is the same for all eight connectors. To reduce lead count, you can use one + for several loads.

#### 4.7.1 Connection of lighting and exhaust systems

This outputs switch the battery voltage, so the connected load must be able to stand the voltage. Example: If the model is operated with a 12V battery, the connected load should be rated for 12Volt. LEDs must be equipped with suitable resistors.

connector	Right post	Middle post	Right post
X10	(+) MG LED	(-) Masse Fahrakku	(-) MG LED
X11	(+) rotating flasher 1+2	(-) rotating flasher 1	(-) rotating flasher 2
X12	(+) rotating flasher 3+4	(-) rotating flasher 3	(-) rotating flasher 4
X13	(+) cannon	(-) cannon recoil	(-) cannon LED
X14	(+) aux 1 and aux 2	(-) aux 1	(-) aux 2
X15	(+) reverse light and brake light	(-) combat brake light	(-) combat reverse light
X16	(+) signal	(-) signal left	(-) signal right
X17	(+) Exhaust system	(-) Exhaust system heater	(-) Exhaust system motor

*Table 4: Allocation of terminal posts for the lights, exhaust fan, and heater*

The heater from the exhaust system can be connected to X04,too. This output is able to drive up to 5A.

## 4.8 Connecting the speaker (X70)

The speaker connects at the black 2 pole connector (X70). We recommend a 4 ohm speaker. An 8 or 16 ohm speaker may be used but this will result in reduced sound volume. The volume may be adjusted by a RC channel or the potentiometer (**V1**). Use a 2mm screw driver to operate the volume control. When the volume is controlled by a rc channel, the potentiometer (**V1**) has no function.

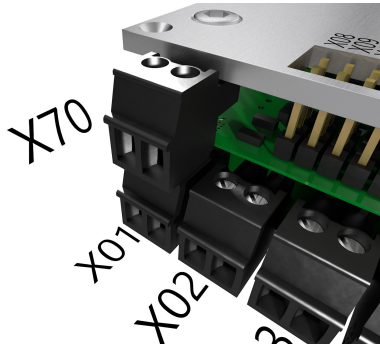

Figure 12: speaker connector

**Tip 1** The speaker needs to be installed in a box to prevent a feedback loop. The presence of a box also improves bass response and sound volume. The box should have as much volume as practical and should not hinder airflow from the face of the speaker.

**Tip 2** In case you want to connect an external audio amplifier, you need an amplifier with an speaker input, or you have to connect an audio transformer.

## 5 Initialization

### 5.1 turn on sequence

1. connect the battery
2. turn on the transmitter
3. all control sticks and trims must be centered
4. turn on the receiver. The LED lights for approximately 1 second.
5. the speed controls sense center point of the channels and the LED on the board flashes. If the operation is not successful the LED does not light. To repeat the operation turn the receiver off and on again
6. if the LED shines the model is ready for operation

This process is repeated at **every** start. The start position of the controls are set as center . This applies to all channels.

When doing the calibration, the optional channels can be left unconnected. In this case the module detects the channels to be unused. You can not connect an optional channel after the calibration finished.

Case one of the not optional channels leaves unconnected, the calibration will not end and the LED keeps on flashing.

### 5.2 operation modes

The green LED 3 on the module shows the active operation mode. The LED flashes like this.

- 1 flash** normal drive mode
- 2 flashes** parking mode
- 3 flashes** model unselected (passive)
- 5 flashes** recovery mode
- 6 flashes** dozer mode

## 6 changing sound and software

The module is delivered with sound and software. So changing sound and software is optional.

You can find the files at this location on our website:

<https://www.sgs-electronic.de/downloads/Full+Option+Modul/TVC-TRF>

To change sound or software, you need a  $\mu$ SD card and basic knowledge how to copy files with your pc.

### 6.1 Changing the sound

You can use the sound files provides on our web site. If you want to change the sound or create your own sound files, you need our FMC software. It is provided for free, on our website.

After powering the module, it detects the  $\mu$ SD card and copies the sound data into the internal sound memory. This is indicated by the green and yellow LED. This sequence takes roughly 30 to 60 seconds. After powering down the module, the  $\mu$ SD card can be removed. It is not needed for operation.

**Always** power off the module before the  $\mu$ SD Card is removed .

### 6.2 Changing the software

The module is equipped with a so called bootloader. After powering the module it checks if a  $\mu$ SD card is plugged and a valid software is stored on the card.

To update or change the kind of model (Battletank, Recoverytank, Anti Aircraft Tank, Armored person carrier), two files have to be copied to the  $\mu$ SD card. When changing the model type, you have to change the sound files, too.

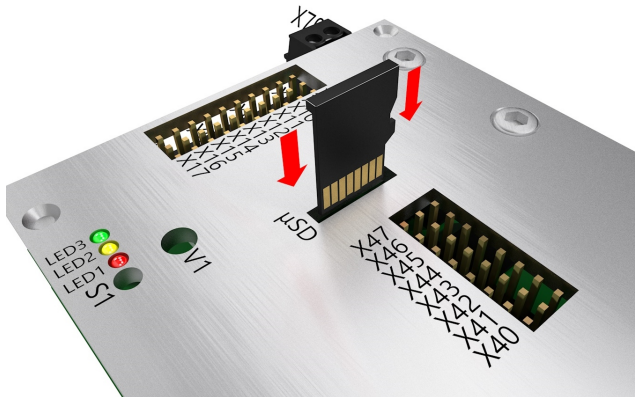

Figure 13: position and orientation of the  $\mu$ SD card slot

2 flashes	config file not found	starts previous image (if loaded)
3 flashes	no program in memory	endless loop
4 flashes	program file not on card	starts previous image (if loaded)
5 flashes	program file not valid for this module	starts previous image (if loaded)
6 flashes	program file crc error	starts previous image (if loaded)

Table 5: boot-loader error codes



## 7 Practical tips

### 7.1 Neutral position

Please use a self centering type joystick or a three stage switch for mode selection. Use of a non self centering stick will result in problems with mode selection due to imprecise neutral position selection.

We suggest using mode channel with

- three stage switch
- self centering sticks, or
- potentiometer with mechanical center indicator

### 7.2 Failsafe receiver

The module calibrates the neutral position of the channels every time you turn on power. If you use a failsafe receiver, please adjust it to deliver the same signals that are delivered when the sticks are in neutral position. Or turn off the failsafe function. Otherwise, the module calibrates the wrong neutral positions.

### 7.3 Do not use provisionally methods of connectivity

Solder or screw all the electrical connections. Provisionally connections can cause high contact resistance, which can lead to problems especially with the battery connection. Isolate open connections using shrink hose or tape.

### 7.4 Work on the wiring

turn off your model **completely** when working at the wiring. Do not plug connectors while the model is powered.

## 7.5 Rotating flasher

The module controls a rotating flasher with four lamps. The lamps are switched in sequence, so no additional electronic is required. Two lamps are connected to X11 and two lamps are connected to X12. Remember that the lighting outputs are at battery voltage. So when the module is powered with 12V the lamps must be rated for 12V. 6V Lamps can be connected using resistors or 5,6V Zener diodes to operate them at 12V supply.

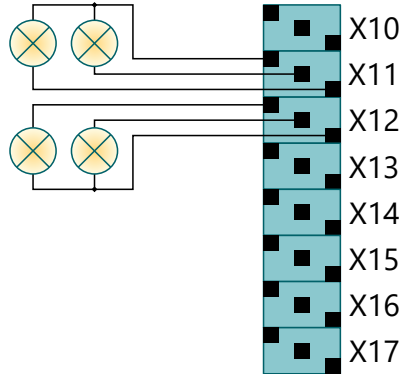

Figure 14: rotating flasher wiring

If you want to connect your own electronic, this can be done by connecting all minus outputs and use them as minus for your flasher.

## 7.6 Connecting LED

When connecting LED, please use suitable resistors. On page 35 correct way to calculate the resistor value is show.

Common resistors are within the scope of delivery .

**Note** Please never connect LED without resistor to the module. This will destroy the LED and/or the module.

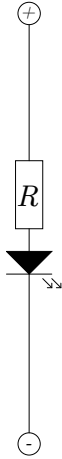

Figure 15: LED resistor

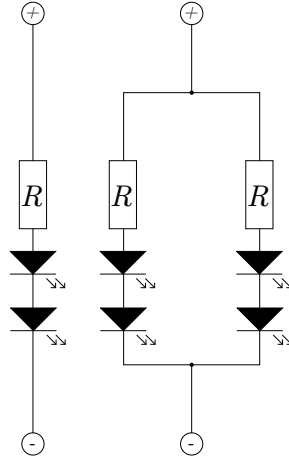

Figure 16: resistor for LED groups

### one LED (diagram 15)

$$\text{resistor} = \frac{\text{batterievoltage} - \text{LEDforwardvoltage}}{\text{LEDcurrent}}$$

example for red LED and 7,2V batterie:

$$\begin{aligned} R &= \frac{7,2V - 1,2V}{0,02A} \\ &= 300\Omega \end{aligned}$$

### multiple LEDs (diagram 16)

$$\text{resistor} = \frac{\text{Akkuspannung} - (\text{LEDforwardvoltage} \times \text{LED count})}{\text{LEDcurrent}}$$

example for two red LEDs and 7,2V batterie:

$$\begin{aligned} R &= \frac{7,2V - 1,2V \times 2}{0,02A} \\ &= 240\Omega \end{aligned}$$

The Summe of the Forward voltages should be min. 2V under the battery voltage. If more LEDs are needed, just switch groups in parallel.

## 8 Glossary of terms

### **BEC** Battery Eliminator Circuit

This circuit replaces a extra Battery needed for the receiver and connected servos, by generating a fixed voltage from the drive battery.

### **ESC** Electronic Speed Controller

This is a unit to control the speed and direction of a DC motor.

### **LED** Light Emmitting Diode

A light-emitting diode (LED) is a semiconductor device that emits visible light when an electric current passes through it. Benefits of LEDs are low power requirement and long life. Disadvantages is the more complicated wiring, compared to a classic bulb, it has a polarity and a resistor is needed to limit the current.

**Scalebus** The Scalebus is a development of **SGS electronic** to connect controllers and modules to compose solutions for complex RC models.

**SBus** The Sbus has been introduced by **Futaba** to simplify the wiring between RC Receivers and servos / esc.

**SBus** The SBus was introduced by the company **Futaba** to simplify the wiring between receiver and servos/controllers. This is especially useful for models with many controllers.

**IBus** The IBus was introduced by the company **Flysky** to simplify the wiring between receiver and servos/controllers. This is especially useful for models with many controllers.

**SUMD** The SUMD sum signal has been introduced by the company **Graupner** to simplify the wiring between receiver and servos/controllers. This is especially useful for models with many controllers.

<b>Abbreviation</b>	<b>meaning</b>	<b>explanation</b>
Stick	Stick	Stick not self centering
StickS	Stick Selfcentering	self centering Stick
TSMS	Three Stage Momentary Switch	self centering momentary switch with three stages
TSS	Three Stage Switch	switch with three stages
Pot	Potentiometer	linear- or rotary knob
PotC	Potentiometer with Center key	linear- or rotary knob with a center key

*Table 6: Abbreviation for the manipulators in the transmitter housing*

## 9 Technical data

rated motor current X01 and X02	10 amp per motor
rated motor current X03, X04, X20 and X21	3 amp per motor
PWM frequency motor outputs	16kHz
rated voltage drop in motor stage	0,3 Volt
rated current X08 to X17	0,4 amp per chanel
rated power audio amplifier	8W/7V; 14W/12V
supply voltage	7,2V bis 16V (equals 12V pb battery / max 11 pb cells / max 12 NiCd/NiMh cells / max 4S Lipo)
rated current BEC servo outputs	1000mA
rated current BEC receiver output	800mA
maximum power disipation	5 Watt
maximum operation temperature	75°C
diemnsions without connectors	65x75x34mm

## 10 Important

This equipment described above has been tested and inspected for quality and function. And it is intended for installation and use only as described above. This equipment does not contain any user serviceable parts. The supplier accepts no responsibility, financially or otherwise, for damages caused by use or misuse of the equipment described above. The equipment must be protected from exposure to water to prevent short circuit. Do not open the equipment or attempt to change function, wiring, or documentation in any way. Do not connect to incorrect voltage or reverse the battery polarity. Do not use in a careless or abusive fashion around persons or property. Do not attempt to repair. Any legitimate use, e.g. Installation in a model makes the user responsible to ensure that the operating instructions and non-liability agreement are provided to the purchaser of the module described above.

Do operate the device only in the permissible operating conditions. Do not make any changes to the controller through. The device shall not be exposed to splashing water or rain (causing a short circuit).

### 10.1 Warning

Due to choking hazard caused by small parts that may be swallowed, this product is not suitable for children under 6 years of age.

### 10.2 Environmental protection

For defective devices, repair is possible in many cases. Please contact us. If you do decide to dispose of the device, you will be making a contribution to environmental protection if you return the device to a municipal collection point for recycling. Electronic devices do not belong in household waste.

### 10.3 Address

SGS electronic  
Zeppelinstraße 36  
47638 Straelen  
Germany / Europe

### 10.4 Contact

**Web** [www.sgs-electronic.de](http://www.sgs-electronic.de)  
**Email** [info@sgs-electronic.de](mailto:info@sgs-electronic.de)

Ust-IdNr.: DE 249033623  
WEEE-Reg.-Nr.: DE 90290947

### 10.5 Document date

This document was created on 2024-02-17 12:24:48+01:00

### 10.6 Documentation

We reserve the right to make updates, changes or additions to the information and data provided.

The documentation that accompanies your product applies.

Please note that documents obtained later via download may not correspond to the status of your module.