

TVC-TC-13

Turret control for model anti aircraft tanks

The module is used to reduce or completely eliminate the wiring between the tower and a TVC-TRF10-AAT or TVC-MF10-AAT installed in the hull.

For this purpose, all servo, motor, light and switch lines of the tower are no longer connected directly to the Full Option Modul, but to the TVC-TC13.

The TVC-TC13 receives the control information via the Scalebus. The Scalebus connection can be:

- four electrical lines of the Scalebus directly, or
- fed through a rotary slip ring unit, or
- wireless, by means of infrared data transmission

realized.

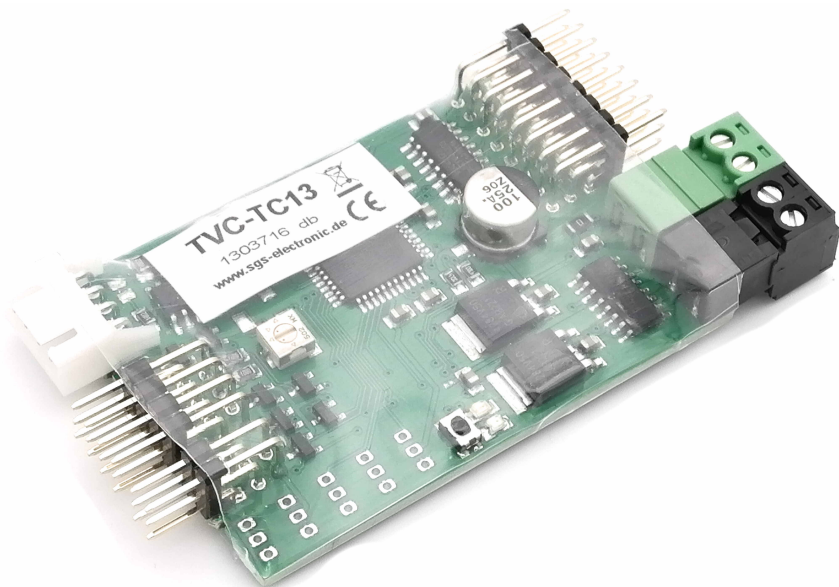

1 Note

Installation of the module requires intermediate to advanced modeling skills. Soldering skills are required to connect the wiring. Inexperienced modelers and persons aged under 16 years old should seek the assistance of an experienced modeler. Always switch off power when working on the wiring. Especial take care when connecting more than one receiver energy source. Prevent the device from getting wet. Check loads before connecting them to the modul at a current limited, or fuse protected source.

Contents

1 Note	2
2 Introduction	5
3 function	6
4 connections	6
4.1 search radar motor	7
4.2 Battery	7
4.3 Servos	7
4.4 Scalebus connection	8
4.5 rotating flashers	8
4.5.1 rotating flasher modul (MRKL)	8
4.5.2 rotating flasher single bulbs	9
4.6 35mm gun flash	9
4.7 Connection of the sensor for the parking position of the search radar	9
5 commissioning	10
6 Glossary of terms	11
7 Technical data	13
8 Important	14
8.1 Warning	14
8.2 Environmental protection	14
8.3 Address	15
8.4 Contact	15
8.5 Document date	15
8.6 Documentation	15

List of Figures

1 Connectors	6
------------------------	---

- 2 Assignment of the connectors for servo outputs, battery connection and tower motor 7
- 3 Assignment of the connector for the power supply 7
- 4 Assignment of the plug connectors for inputs and switching outputs 8

List of Tables

- 1 Abbreviation for the manipulators in the transmitter housing 12

2 Introduction

The module controls the gun elevation, the tower rotation, rotation and tilt of the slave radar, as well as the automatic retraction and extension of the search radar.

In addition, the parking sensor in the search radar is evaluated and the search radar arm motor is switched.

The control of the gun elevation, rotation and inclination of the follower radar, as well as the retraction and extension of the search radar are controlled via servo. A speed controller is already integrated for controlling the search radar motor. The speed of the search radar motor can be adjusted via a potentiometer. The turret motor is still connected directly to the Full Option Modul in the hull.

The TVC-TC13 receives the control information via the Scalebus. The Scalebus connection can be:

- four electrical lines of the Scalebus directly, or
- fed through a rotary slip ring unit, or
- wireless, by means of infrared data transmission

realized.

For wireless transmission, two additional Scalebus infrared repeaters GFMC-SBR10 are required.

The power supply of the module can be done via two lines from the drive battery in the hull via two lines from the drive battery in the hull. Together with the scale bus, six lines/loop-ring contacts are then required between the hull and the tower.

If the connection is made via infrared repeater, a battery with min. 7.2 V must be provided in the tower for power supply, which supplies the consumers in the tower. A battery capacity of 200mAh is already sufficient. An integrated BEC provides for the 5V supply for the servos.

3 function

The module mirrors the tower functions of the Full Option Modul module TVC-TRF10-AAT or TVC-MF10-AAT .

The pin assignment for servos corresponds to those of the Full Option Modul module. Please note that the pin assignment of the parking position sensor on the TVC-TC13 does NOT correspond to that of the Full Option Modul module.

The output for the gear motor is located on the black socket and it is adjustable in speed via P1.

While the Full Option Modul has four outputs for the rotating flasher light, the tower module offers an additional output for an automaticrotating flasher.

4 connections

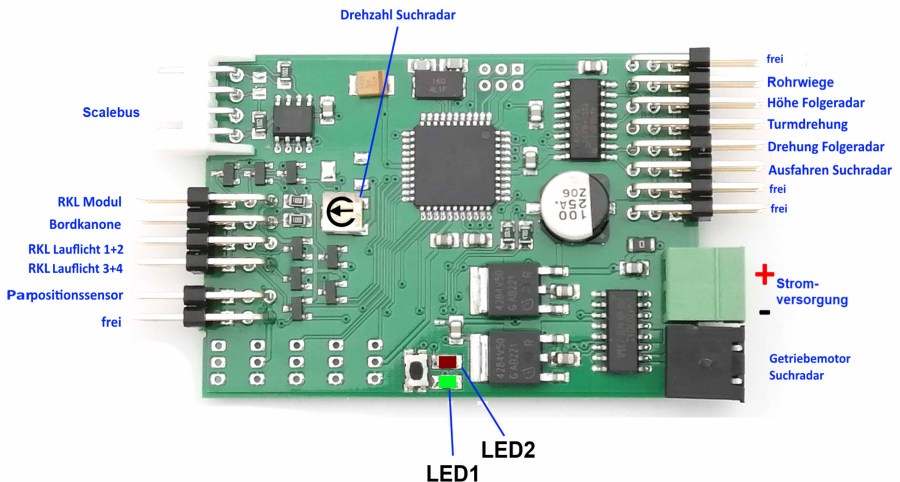

Figure 1: Connectors

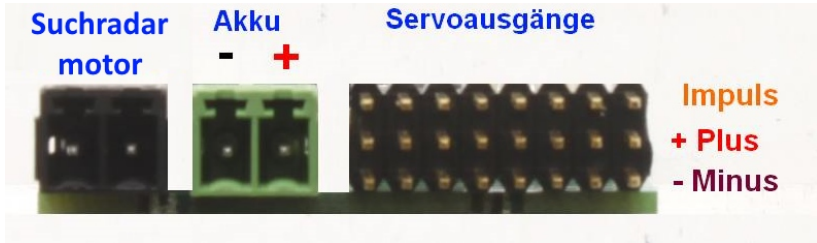

Figure 2: Assignment of the connectors for servo outputs, battery connection and tower motor

4.1 search radar motor

The search radar motor is connected according to Fig. 2 (S. 7).

4.2 Battery

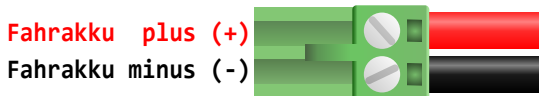

Figure 3: Assignment of the connector for the power supply

The module has its own BEC. A plug-in screw terminal is provided for the battery. Please note the polarity of the supply voltage.

4.3 Servos

Before you install the servos, check the direction of rotation. Also make sure that the servos reach the end positions. Otherwise a possible mechanical blockage can cause an increased current consumption of the BEC.

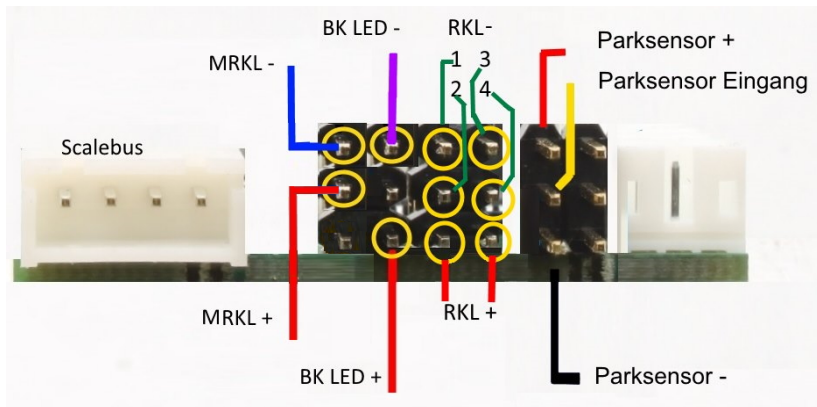

Figure 4: Assignment of the plug connectors for inputs and switching outputs

4.4 Scalebus connection

The Scalebus connection is made by a four-pole cable. To realize infinite rotation of the tower on the hull, a scale bus repeater GFMC-SBR-10 can also be connected in between. Since the module has its own BEC controller, it then supplies itself and the Scalebus repeater from the battery for the tower. The repeater in the hull is supplied via the Full Option Modul.

4.5 rotating flashers

Automatic rotating flasher modules or four individual bulbs can be connected.

4.5.1 rotating flasher modul (MRKL)

Make sure that the voltage range of the rotating flasher matches the battery voltage applied to the battery connector.

4.5.2 rotating flasher single bulbs

The four outputs (green) are connected to the incandescent lamps in an rotating flasher housing (e.g. Wedico). When using LEDs, appropriate series resistors must be connected.

4.6 35mm gun flash

A high-current LED can be connected directly to the module. This is switched on for approx. 300ms when the shot is triggered. The output switches max. 500mA against accumulator+. Adjust the current with a suitable resistor.

4.7 Connection of the sensor for the parking position of the search radar

Electrically, the sensor can be used as a mechanical contact (e.g. reed contact) or an electronic magnetic sensor. Mechanical contacts (reed contact) are connected to minus and the input. The input must not remain open. The module checks if a change from open to closed happens before it retracts the servo. If the input remains open, this change does not happen and the servo does not move in/out. To support you during start-up, the switching state of the parking sensor is displayed with LED 2. If the radar should be in park position the LED is off, but the active park sensor switches the LED on. If the LED is permanently on, the active parking sensor switches the LED off.

5 commissioning

No special commissioning is necessary. As soon as the module is connected to the Full Option Module via the Scalebus, it mirrors its functions. You should familiarize yourself with the function step by step, especially if the servos are not yet installed in the model. This way you can control the direction of action and range of travel without causing any damage to the model.

The speed of the search radar motor can be set at potentiometer P1. The gearmotor continues to run after the parking sensor has been detected and switched off by the module. The distance covered, and thus also the actual parking position, depends on the speed. LED 1 lights up continuously to indicate that the scale bus is active. If the LED flashes, no messages are being received.

LED 2 indicates the status of the search radar. Continuous illumination indicates that the radar is to be extended.

Tip Servos that do not reach the end position because they are mechanically blocked will hum audibly. They then also draw significantly higher currents. This current can be so high that it reaches the current limit of the BEC controller. Please make sure that the servos run freely.

For infrared operation, you can connect the scale bus directly for commissioning or fix the repeaters mechanically so that the tops of the repeaters are opposite each other.

6 Glossary of terms

BEC Battery Eliminator Circuit

This circuit replaces a extra Battery needed for the receiver and connected servos, by generating a fixed voltage from the drive battery.

ESC Electronic Speed Controller

This is a unit to control the speed and direction of a DC motor.

LED Light Emmitting Diode

A light-emitting diode (LED) is a semiconductor device that emits visible light when an electric current passes through it. Benefits of LEDs are low power requirement and long life. Disadvantages is the more complicated wiring, compared to a classic bulb, it has a polarity and a resistor is needed to limit the current.

Scalebus The Scalebus is a development of **SGS electronic** to connect controllers and modules to compose solutions for complex RC models.

SBus The Sbus has been introduced by **Futaba** to simplify the wiring between RC Receivers and servos / esc.

SBus The SBus was introduced by the company **Futaba** to simplify the wiring between receiver and servos/controllers. This is especially useful for models with many controllers.

IBus The IBus was introduced by the company **Flysky** to simplify the wiring between receiver and servos/controllers. This is especially useful for models with many controllers.

SUMD The SUMD sum signal has been introduced by the company **Graupner** to simplify the wiring between receiver and servos/controllers. This is especially useful for models with many controllers.

Abbreviation	meaning	explanation
Stick	Stick	Stick not self centering
StickS	Stick Selfcentering	self centering Stick
TSMS	Three Stage Momentary Switch	self centering momentary switch with three stages
TSS	Three Stage Switch	switch with three stages
Pot	Potentiometer	linear- or rotary knob
PotC	Potentiometer with Center key	linear- or rotary knob with a center key

Table 1: Abbreviation for the manipulators in the transmitter housing

7 Technical data

Rated motor current	5 Ampere
Short-circuit proof against ground, supply and terminal closure, overload proof and overtemperature proof	
Supply voltage (without BEC)	5 bis 24 V
Supply voltage (with BEC)	6,5 bis 24 V
Allowable BEC current	800mA
PWM frequency	2kHz
Typical maximum power dissipation	25 Watt
Typical voltage drop in the output stage	1.5 Volt
Dimensions	62x41x18mm
Software version	01.02.06

8 Important

This equipment described above has been tested and inspected for quality and function. And it is intended for installation and use only as described above. This equipment does not contain any user serviceable parts. The supplier accepts no responsibility, financially or otherwise, for damages caused by use or misuse of the equipment described above. The equipment must be protected from exposure to water to prevent short circuit. Do not open the equipment or attempt to change function, wiring, or documentation in any way. Do not connect to incorrect voltage or reverse the battery polarity. Do not use in a careless or abusive fashion around persons or property. Do not attempt to repair. Any legitimate use, e.g. Installation in a model makes the user responsible to ensure that the operating instructions and non-liability agreement are provided to the purchaser of the module described above.

Do operate the device only in the permissible operating conditions. Do not make any changes to the controller through. The device shall not be exposed to splashing water or rain (causing a short circuit).

8.1 Warning

Due to choking hazard caused by small parts that may be swallowed, this product is not suitable for children under 6 years of age.

8.2 Environmental protection

For defective devices, repair is possible in many cases. Please contact us. If you do decide to dispose of the device, you will be making a contribution to environmental protection if you return the device to a municipal collection point for recycling. Electronic devices do not belong in household waste.

8.3 Address

SGS electronic
Zeppelinstraße 36
47638 Straelen
Germany / Europe

8.4 Contact

Web www.sgs-electronic.de
Email info@sgs-electronic.de

Ust-IdNr.: DE 249033623
WEEE-Reg.-Nr.: DE 90290947

8.5 Document date

This document was created on 2025-03-14 17:02:55+01:00

8.6 Documentation

We reserve the right to make updates, changes or additions to the information and data provided.

The documentation that accompanies your product applies.

Please note that documents obtained later via download may not correspond to the status of your module.

